

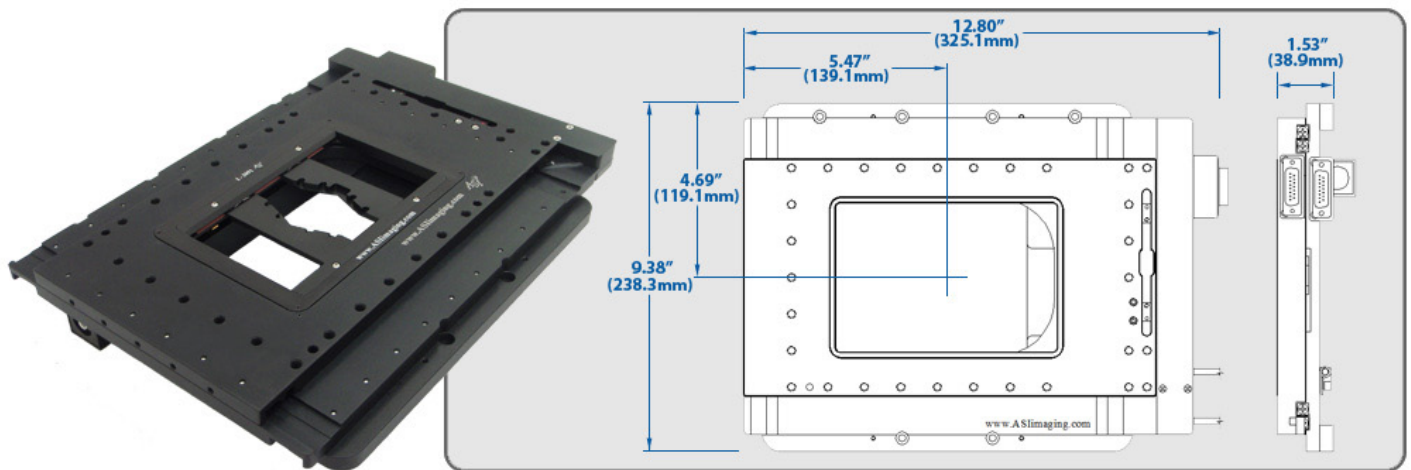

APPLIED SCIENTIFIC  
INSTRUMENTATION

## Ultra-Stable US-2000 Flat Top XYZ Automated Stage for Super Resolution



The US-2000 Flat Top XY stage has been specifically designed to provide an ultra-stable, high resolution, and highly repeatable means of controlling the X, Y position of the microscope stage for superior resolution microscopy applications. The stage can be used in conjunction with ASI's proven line of Z-axis motor drives, each custom fitted to the microscope for complete XYZ positioning. All axes derive their precise control through the use of closed loop DC servomotors employing high resolution rotary encoders for positioning feedback. For ultra high precision Z focusing piezos can be embedded within the top plate of the stage in travel ranges of 150, 300, or 500 microns. The US-2000 XY stage utilizes crossed-roller slides, a high precision lead screw, and zero backlash miniature geared DC servomotors for smooth and accurate motion. XY travel ranges from 25mm to 120mm are available. To minimize thermal drift it is best to choose the 25mm travel range as it uses a smaller lead screw to reduce thermal variations at the sample. With the optional linear encoders and 0.635mm pitch lead screws resolutions of 2.5nm with true optical resolutions of 10nm at the sample are available. The micro-processor controlled MS-2000 control unit provides for RS-232 and USB communication with a host computer. Systems are available for all standard research grade microscopes and OEM applications.

### US-2000 Options

- Piezo top plates with Z ranges of 150, 300 and 500 nm
- Larger stage top plate for attachment of micromanipulators, microinjectors, etc...
- Stage wings for even more room for attachments
- Auto-focus for stages with ASI Z-axis drives (requires NTSC, PAL, or S-Video analog signal)
- Other lead screw pitches are available

# Ultra-Stable US-2000 Flat Top XYZ Automated Stage for Super Resolution

## US-2000 Features

- Closed loop DC servo control of the X, Y, and Z-axes for precise positioning and highly repeatable focusing
- Wide dynamic speed range with XY joystick
- Utilizes ASI's proven Z-Axis drives
- Z-axis clutch for easy switching between manual and motor driven focus control
- Backlit LCD display shows X, Y, and Z coordinates
- "Zero" and "Home" buttons for simple stand-alone operations
- Compact, ergonomic tabletop control unit size is 6"D x 9"W x 3"H (9 x 23 x 16.5 cm)
- Microprocessor control with RS-232 serial and USB communications
- Travel Range will scan full well plate in most circumstances
- Proven operation with many popular software packages

## Lead Screw Options

Lead Screw Pitch Options	Rotary Encoder Resolution	Maximum Speed
25.40 mm (Ultra-coarse)	88 nm	28 mm/sec
12.70 mm (Super-coarse)	44 nm	14 mm/sec
6.35 mm (Standard)	22 nm	7 mm/sec
1.59 mm (Fine)	5.5 nm	1.75 mm/sec
0.635 mm (Extra-fine)	2.2 nm	0.7 mm/sec

\* Standard Lead Screw Accuracy is 0.25  $\mu$ m per millimeter

## Specifications for Standard Configuration

<b>XY axis range of travel</b>	25 x 25 mm up to 120mm x 75mm
<b>XY axis resolution (encoder step)</b>	2.5 nm (10nm at optical axis)
<b>XY axis RMS repeatability</b>	< 200 nm
<b>XY axis maximum velocity (dependent on lead screw pitch option)</b>	0.635 mm/sec
<b>Z axis resolution with optional piezo top plate</b>	2.2nm with 16 bit DAC 1.1nm with 17 bit DAC
<b>Z axis repeatability with optional piezo top plate</b>	+/- 2 nm
<b>Z axis maximum velocity with optional piezo top plate</b>	~ 10 ms for most moves
<b>Max recommended load</b>	1 kg